

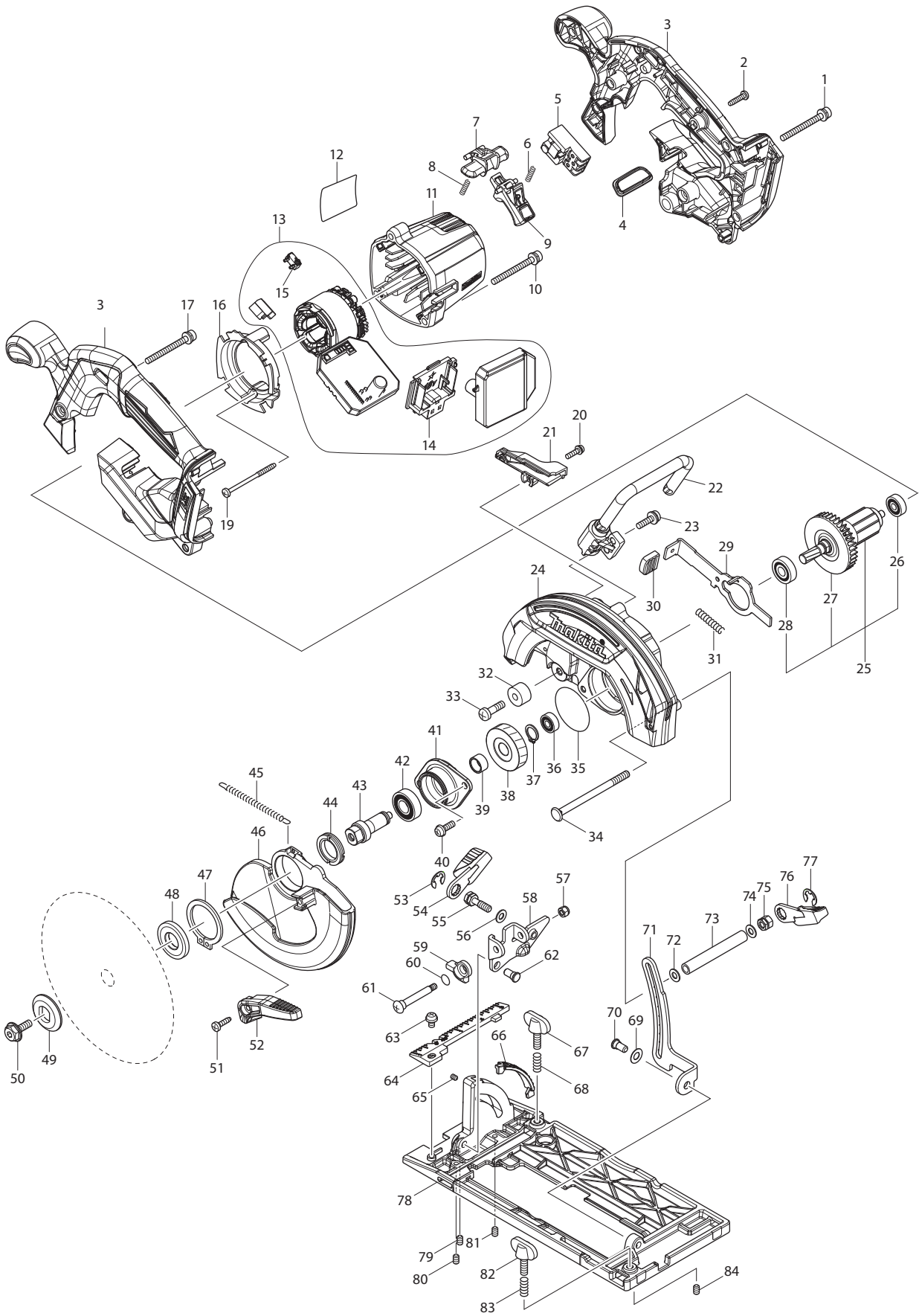

12 - 2014
DHS680Z
18V BL 6-1/2" CIRCULAR SAW



Item No.	Type	Sub	Part No.	Description	Qty	Unit
001			911263-2	PAN HEAD SCREW M5X40	1	PC.
002			265995-6	TAPPING SCREW 4X18	7	PC.
003			183A14-1	HANDLE SET	1	PC.
		INC.	263005-3	RUBBER PIN 6	2	PC.
		INC.	805E05-3	CAUTION LABEL	1	PC.
004			142948-1	INDICATION PLATE COMPLETE	1	PC.
005			650734-1	SWITCH TG73BDS-2	1	PC.
006			231469-9	COMPRESSION SPRING 4	1	PC.
007			419664-3	LOCK OFF LEVER	1	PC.
008			231469-9	COMPRESSION SPRING 4	1	PC.
009			455480-9	SWITCH LEVER	1	PC.
010			911263-2	PAN HEAD SCREW M5X40	3	PC.
011			455437-0	MOTOR HOUSING	1	PC.
012			850H69-0	NAME PLATE F/DHS680	1	PC.
013	2		629348-7	* STATOR UNIT	1	PC.
	3		629B61-9	* STATOR	1	PC.
014			644808-8	TERMINAL	1	PC.
015			632D81-6	SWITCH UNIT	1	PC.
016			455440-1	BAFFLE PLATE	1	PC.
017			911263-2	PAN HEAD SCREW M5X40	1	PC.
019			266091-3	TAPPING SCREW 4X50	2	PC.
020			911128-8	PAN HEAD SCREW M4X16	1	PC.
021			455483-3	DUCT	1	PC.
022			123269-0	HOOK ASSEMBLY	1	PC.
023			911233-1	PAN HEAD SCREW M5X20	2	PC.
024	2		143256-3	BLADE CASE COMPLATE	1	PC.
		INC.	213953-6	O RING 24	1	PC.
025		INC.	519359-9	ROTOR ASS'Y	1	PC.
				Item No. 26-28		
026			210022-4	BALL BEARING 626DDW	1	PC.
027			240045-8	FAN 55	1	PC.
028			210051-7	BALL BEARING 609LLB	1	PC.
029			346837-4	SHAFT LOCK	1	PC.
030			286275-7	CAP	1	PC.
031			233117-6	COMPRESSION SPRING 6	1	PC.
032			262552-1	RUBBER SLEEVE 6	1	PC.
033			251247-1	+ PAN HEAD SCREW M6X20	1	PC.
034			266194-3	FLAT HEAD SCREW M6X90	1	PC.
035			213565-5	O RING 42	1	PC.
036	2		210137-7	BALL BEARING 606ZZ	1	PC.
037			961052-5	RETAINING RING S-12	1	PC.
038			227794-4	HELICAL GEAR 50	1	PC.
039			257349-1	SLEEVE 12	1	PC.
040			911223-4	PAN HEAD SCREW M5X16	2	PC.
041			319212-7	BEARING BOX	1	PC.
042			211131-2	BALL BEARING 6001DDW	1	PC.
043			326459-6	SPINDLE	1	PC.
044			285845-9	BEARING RETAINER 19-29	1	PC.
045			231878-2	TENSION SPRING 4	1	PC.
046			319211-9	SAFETY COVER	1	PC.
047			961152-1	RETAINING RING (EXT) S-34	1	PC.
048			224411-7	INNER FLANGE 35	1	PC.
049			224409-4	OUTER FLANGE 35	1	PC.
050			266924-2	HEX. SOCKET HEX. BOLT M6X18	1	PC.
051			266034-5	TAPPING SCREW CT 4X16	1	PC.
052			272282-6	LEVER 60	1	PC.

Item No.	Type	Sub	Part No.	Description	Qty	Unit
053			257982-9	BOW STOP RING E-8	1	PC.
054			272272-9	LEVER 45	1	PC.
055	2		265B21-3	* HEX.BOLT M6X20	1	PC.
057			252103-8	HEX. LOCK NUT M5-8	1	PC.
058			346836-6	ANGULAR GUIDE	1	PC.
059			317986-4	STOPPER	1	PC.
060			213062-1	O RING 9	1	PC.
061			265084-7	+ TRUSS HEAD SCREW M5	1	PC.
062			256480-0	SHOULDER PIN 6-7	1	PC.
063	2		911208-0	PAN HEAD SCREW M5X10 W/Washer	1	PC.
064			455515-6	TOP GUIDE	1	PC.
065			266318-1	H.S.SET SCREW(FLAT POINT)M4X6	2	PC.
066			455517-2	BEVEL GUIDE	1	PC.
067			251896-4	SCREW M5X20	1	PC.
068			231007-7	COMPRESSION SPRING 6	1	PC.
069			253058-0	* FLAT WASHER 7 (Removed)	1	PC.
070			256511-5	SHOULDER PIN 6-7	1	PC.
071			346835-8	DEPTH GUIDE	1	PC.
072			941151-9	FLAT WASHER 6	1	PC.
073			332126-3	PIPE 6	1	PC.
074			941151-9	FLAT WASHER 6	1	PC.
075			264103-6	HEX. NUT M6	1	PC.
076			272272-9	LEVER 45	1	PC.
077			257982-9	BOW STOP RING E-8	1	PC.
078	2		312B04-5	* BASE	1	PC.
079			266436-5	H.S.SET SCREW(FLAT POINT)M5X8	1	PC.
080			266436-5	H.S.SET SCREW(FLAT POINT)M5X8	1	PC.
081			266436-5	H.S.SET SCREW(FLAT POINT)M5X8	1	PC.
082			251896-4	SCREW M5X20	1	PC.
083			231007-7	COMPRESSION SPRING 6	1	PC.
084			266436-5	H.S.SET SCREW(FLAT POINT)M5X8	1	PC.
085			253077-6	FLAT WASHER 6	1	PC.
086			620K93-3	* CONTROLLER (Added)	1	PC.
087			652119-7	* PH SCREW M2X6 (Added)	6	PC.
C01			876865-0	CARTON	1	PC.
E01			805E06-1	CAUTION LABEL	1	PC.

ACCESSORIES

- See Catalogue or visit www.makita.ca for more accessories information -

A01			783203-8	HEX. WRENCH 5	1	PC.
A02			A-85092	6-1/2" C.T.SAW BLADE 24T	1	PC.
A03			-----	18V LI-ION BATTERY		
A04			-----	BATTERY CHARGER		
A05			-----	LI-ION BATTERY ACCESSORIES		
A06	2		196952-2	DUST NOZZLE	1	PC.
		INC.	272281-8	LEVER 39 (N/A individually)	1	PC.
A07			164095-8	GUIDE RULE (RIP FENCE)	1	PC.
A08			194368-5	GUIDE RAIL 1400MM	1	PC.
A09			194925-9	GUIDE RAIL 1900MM	1	PC.
A10			194367-7	GUIDE RAIL 3000MM	1	PC.
A11	2		196953-0	* GUIDE RAIL ADAPTER SET	1	PC.
		INC.	346843-9	* RULE BAR D (Added)	2	PC.
A13			MK403-M	CONSTRUCTION WORK GLOVES M	1	PC.
			MK403-L	CONSTRUCTION WORK GLOVES L	1	PC.
			MK403-XL	CONSTRUCTION WORK GLOVES XL	1	PC.
			MK404-M	IMPACT WORK GLOVES M	1	PC.
			MK404-L	IMPACT WORK GLOVES L	1	PC.

Item No.	Type	Sub	Part No.	Description	Qty	Unit
			MK404-XL	IMPACT WORK GLOVES XL	1	PC.
			MK405-M	DEMOLITION WORK GLOVES M	1	PC.
			MK405-L	DEMOLITION WORK GLOVES L	1	PC.
			MK405-XL	DEMOLITION WORK GLOVES XL	1	PC.
A14			195546-0	FRONT CUFFS 24 (F/ connecting to Vacuum)	1	PC.
			195546-0	FRONT CUFFS 24 (F/ connecting to Vacuum)	1	PC.
A15			199140-0	GUIDE RAIL 1000MM	1	PC.
A16			199141-8	GUIDE RAIL 1500MM	1	PC.
A17			198885-7	GUIDE RAIL CONNECTORS	1	PC.
A18	3		E-10936	GUIDE RAIL BAG 3000MM	1	PC.
A19			196664-7	BEVEL GUIDE SET	1	PC.
A20			194417-8	RUBBER SHEET 384" (10000MM)	1	PC.
A21			194416-0	VINYL SHEET 384" (10000MM)	1	PC.
A22			199826-6	RATCHET CLAMP SET	1	PC.
A23			197212-5	INTERLOCKING TOOL CASE L	1	PC.
A23		INC.	453974-8	LOCKING LATCH	4	PC.
A24			838182-6	INNER TRAY F/INTERLOCKING CASE	1	PC.

SERVICE CHANGES

1. Rule bar D is available for repair

(T/I#Y07220)

Item No.	Description	PN
A11	GUIDE RAIL ADAPTER D SET	196953-0
INC.	RULE BAR D	346843-9

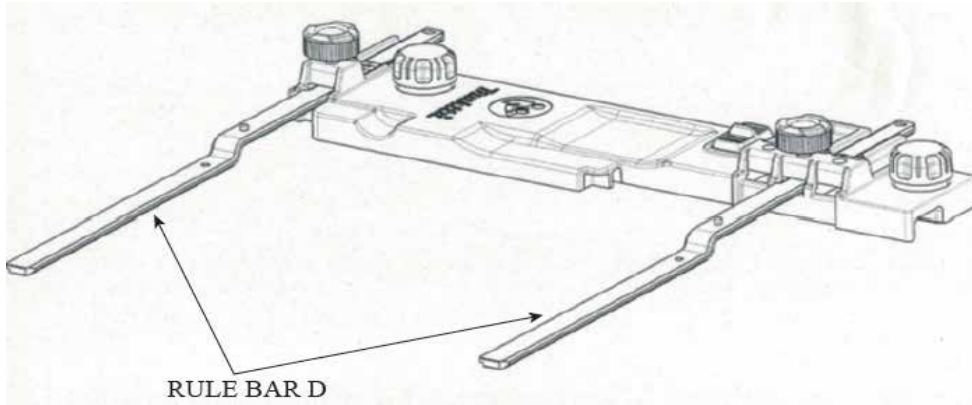

2. Change of Hex Bolt M6x20 and Flat Washer 6

(T/I#D5231)

Item No.	Description	Type 1	Type 2
055	HEX BOLT M6X20	266735-5	265B21-3
056	FLAT WASHER 6	941151-9	-----

3. Change of Base, Elimination of Flat washer 7

(T/I#D7392)

Item No.	Description	Type 1	Type 2
078	BASE	319210-1	312B04-5
069	FLAT WASHER 7	253058-0	-----

Detailed information

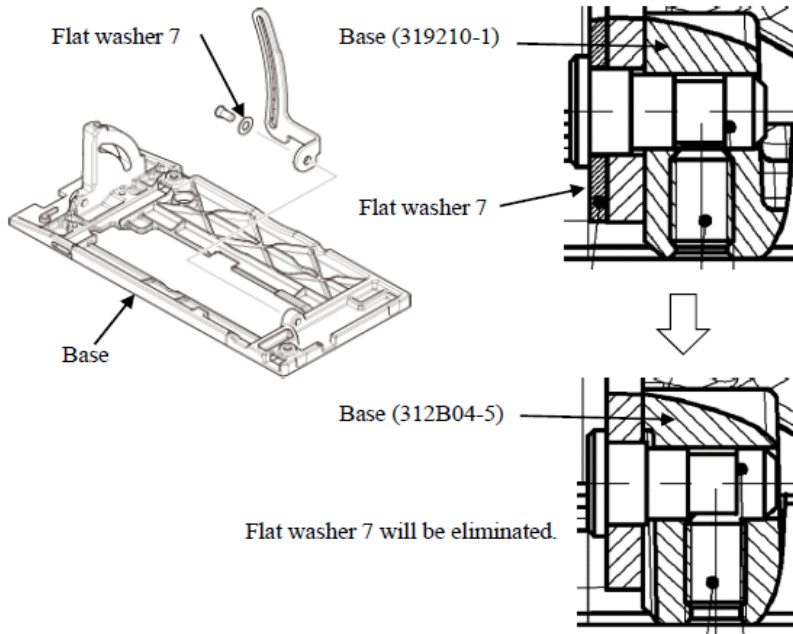

4. Changes on Stator and Controller

(T/I#C0482)

(T/I#DG919)

Item No.	Description	Type 1	Type 2	Type 3
13	STATOR	632D90-5	629348-7	629B61-9
86	CONTROLLER	-----	-----	620K93-3
87	PAN HEAD SCREW M2X6	-----	-----	652119-7

Above parts are completely interchangeable as a set.

See T/I#DG919 for repair and wiring